

NanoSpeed™

Variable Fiber Optical Attenuator

(SMF, PMF, High Power)

(Protected by U.S. patent 7,403,677B1 and pending patents)

Product Description

The NS Series Variable Fiber Optical Attenuator (VOA) provides electrical control of optical power. This is achieved using a patent pending non-mechanical configuration and activated via a voltage electrical control signal. The solid-state optical crystal design eliminates mechanical movement and organic materials. The NS Series Variable Optical Attenuators are designed to meet the most demanding operation requirements of ultra-high reliability and fast response time with minimal mechanical footprint. Agiltron also offers customized electronic designs to meet special control requirements and applications. The switch is bidirectional.

The NS Series VOA is available in either normally-transparent or normally-opaque configurations. The NS Series VOA is controlled by 5V TTL signals with a specially designed electronic driver having performance optimized for various repetition rate.

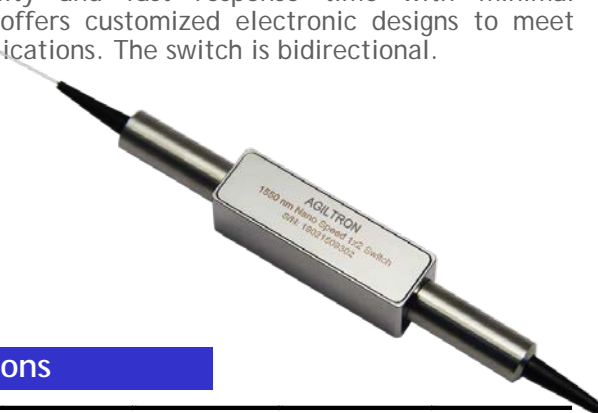

Performance Specifications

NanoSpeed Series VOA	Min	Typical	Max	Unit
Central wavelength ^[1]	780		1650	nm
Insertion Loss ^[2]	1260-1650nm	0.6	1.0	dB
	960-1100nm	0.8	1.3	
	780-960nm (Normal power VOA only)	1.0	1.5	
Attenuation Range ^[3]	20	28	36	dB
PDL (SMF VOA only)		0.1	0.3	dB
PMD (SMF VOA only)		0.1	0.3	ps
ER (PMF VOA only)	18	25		dB
Resolution		Continuous		dB
Return Loss	45	50	60	dB
Fiber Type	SMF-28, Panda PM, or equivalent			
Modulation Rate	5kHz driver	DC	5	kHz
	20kHz driver	DC	20	
	100kHz driver	DC	100	
5MHz Modulation Rate ^[4]	0.1		5	MHz
Optic power Handling ^[5]	Normal power VOA		300	mW
	High power VOA		5	W
Operating Temperature	-5		70	°C
Storage Temperature	-40		85	°C

[1] Operation bandwidth is +/- 25nm approximately at 1550nm.

[2] Measured without connectors. For other wavelength, please contact us.

[3] Full attenuation is measured at 5kHz, which may be degraded at the high repeat rate.

[4] Special circuit, maximum modulation depth is 5-10%.

[5] Defined at 1310nm/1550nm. For the shorter wavelength, the handling power may be reduced, please contact us for more information.

Features

- Solid-State
- High speed
- U-High reliability
- Low insertion loss
- Compact

Applications

- Optical blocking
- Configurable operation
- Instrumentation



NanoSpeed™ Variable Fiber Optical Attenuator (SMF, PMF, High Power)

Mechanical Dimensions (mm)

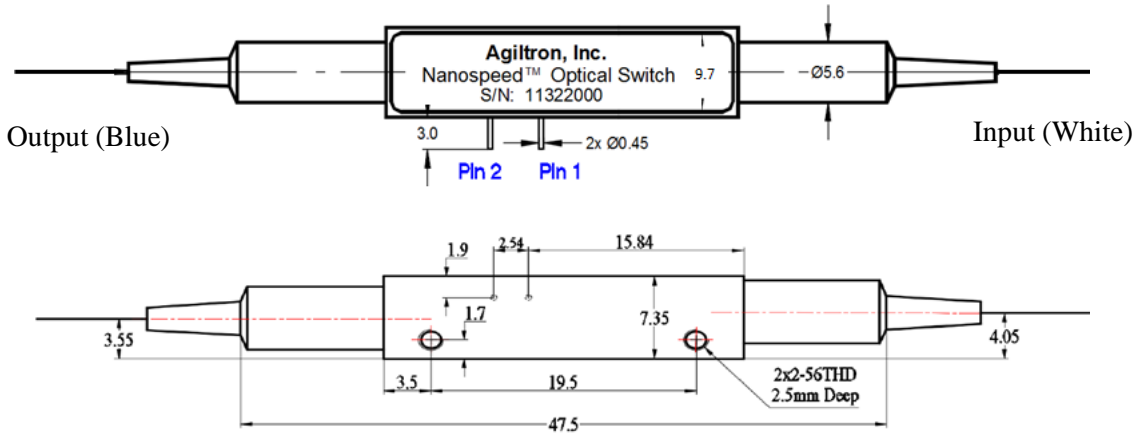

Normal Power VOA

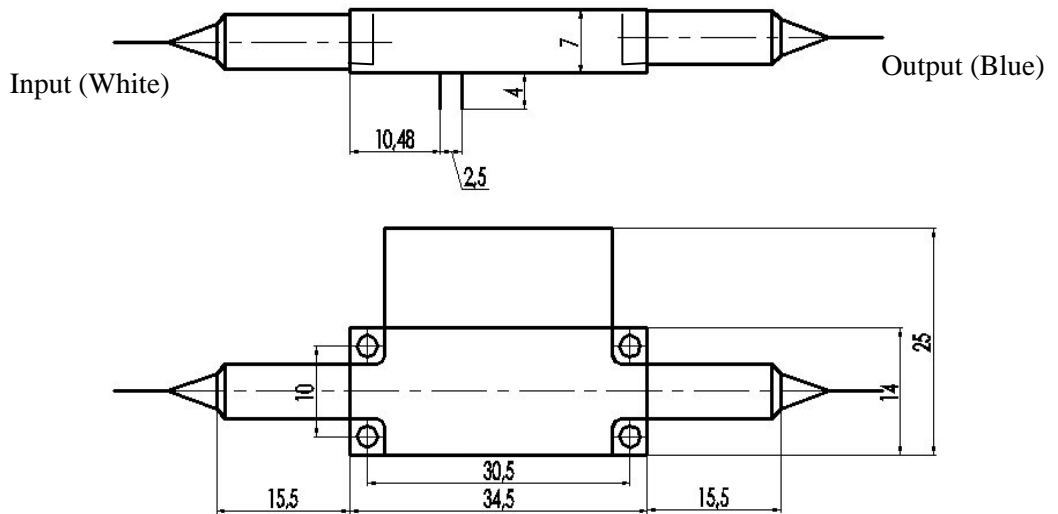

High Power VOA (Option 1, 0.5 < P < 2W)

*Product dimensions may change without notice. This is sometimes required for non-standard specifications.

NanoSpeed™ Variable Fiber Optical Attenuator (SMF, PMF, High Power)

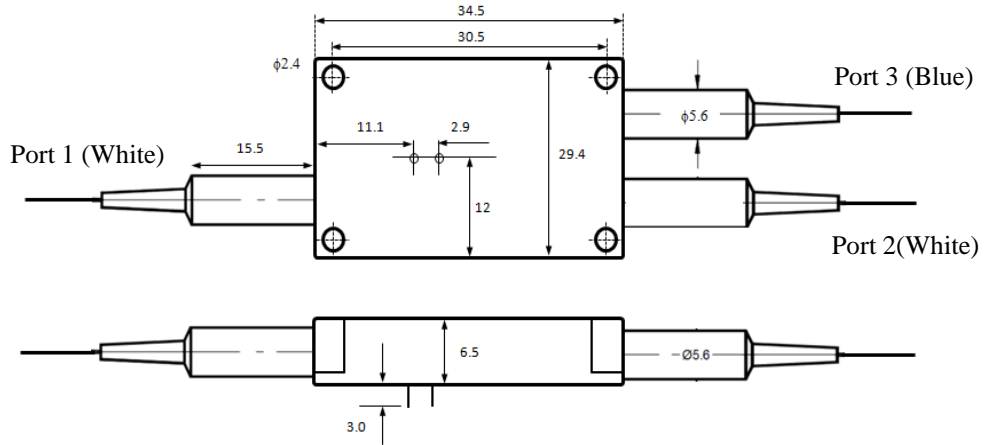

High Power VOA (Option 2, P > 2W)

Typical Attenuation versus Voltage

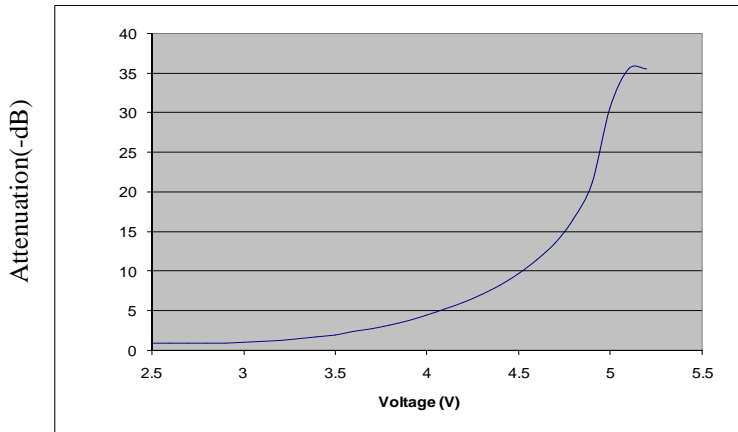

* Measured with Agiltron's NVDR driver

Driving Board Selection

Maximum Repetition Rate	Part Number (P/N)
5kHz	NVDR-111221112
20kHz	NVDR-113235112
100kHz	NVDR-112221112

* Note: For customers that prefer to design their own driving circuit, they are responsible for the optical performance. For more technical information, please contact us.

NanoSpeed™ Variable Fiber Optical Attenuator (SMF, PMF, High Power)

Typical High Speed Response

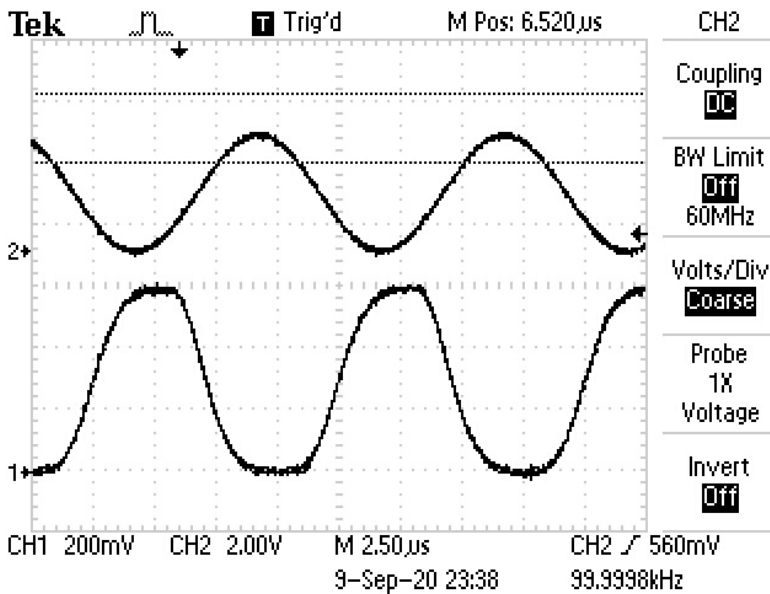
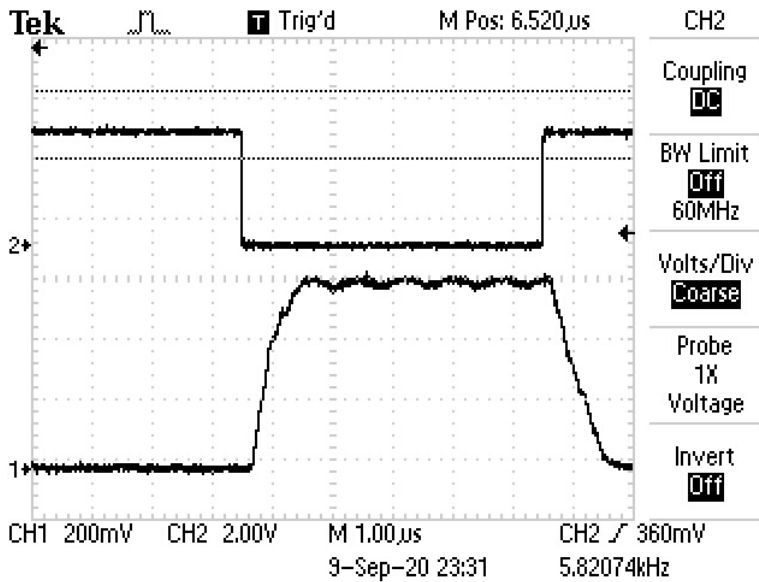

NanoSpeed™ Variable Fiber Optical Attenuator (SMF, PMF, High Power)

Typical WDL @10dB attenuation

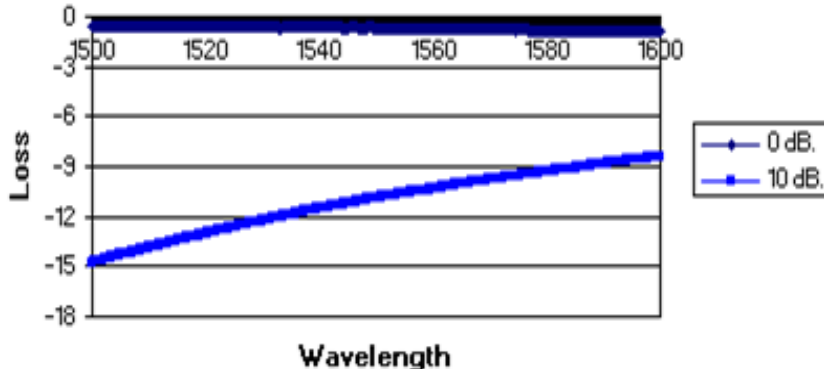

Ordering Information

<input type="checkbox"/> <input type="checkbox"/> <input type="checkbox"/> <input type="checkbox"/> - <input type="checkbox"/> <input type="checkbox"/> <input type="checkbox"/> <input type="checkbox"/> <input type="checkbox"/> <input type="checkbox"/> <input type="checkbox"/> <input type="checkbox"/>							
	Type	Wavelength [2]	Configuration	Fiber Type	Fiber Length	Connector [3]	
NVOA = Normal power VOA	32 Special=00	1060 nm=1 L Band=2 1310 nm=3 1410 nm=4 1550 nm=5 780 nm=7 850 nm=8 Special=0	Transparent & single stage =11 (<0.5W) Opaque & single stage = 21 (<=0.5W) Transparent & single stage =1A (0.5W< P<2W) Opaque & single stage = 2A (0.5 < P<2W) Transparent & single stage =1B (P >2W) Opaque & single stage = 2B (P >2W) Special = 00	SMF-28=1 HI 1060=2 HI 780=3 PM 1550/250=B PM 1400/250=C PM 1310/250=D PM 980/250=E PM 850/250=F Special=0	Bare fiber=1 900um tube=3 Special=0	0.25 m=1 0.5 m=2 1.0 m=3 Special=0	None=1 FC/PC=2 FC/APC= 3 SC/PC=4 SC/APC=5 ST/PC=6 LC/PC=7 Duplex LC=8 LC/APC=9 Special=0

[2]. High power VOA isn't available for the wavelength shorter than 960nm.

[2]. There isn't any connector in the high power VOA normally. Please contact us for high power connectors.



NanoSpeed™ Variable Fiber Optical Attenuator (SMF, PMF, High Power)

Q&A

Q: Does NS device drift over time and temperature?

A: NS devices are based on electro-optical crystal materials that can be influenced to a certain range by the environmental variations. The insertion loss of the device is only affected by the thermal expansion induced miss-alignment. For extended temperature operation, we offer special packaging to -40 -100 °C. The extinction or cross-talk value is affected by many EO material characters, including temperature-dependent birefringence, V_p , temperature gradient, optical power, at resonance points (electronic). However, the devices are designed to meet the minimum extinction/cross-talk stated on the spec sheets. It is important to avoid a temperature gradient along the device length.

Q: What is the actual applying voltage on the device?

A: 100 to 400V depending on the version.

Q: How does the device work?

A: NS devices are not based on Mach-Zander Interference, rather birefringence crystal's nature beam displacement, in which the crystal creates two different paths for beams with different polarization orientations.

Q: What is the limitation for faster operation?

A: NS devices have been tested to have an optical response of about 300 ps. However, practical implementation limits the response speeds. It is possible to achieve a much faster response when operated at partial extinction value. We also offer resonance devices over 20MHz with low electrical power consumption.