

- Low Noise
- High Sensitivity
- 200um Active Area
- Standard TO46 Package
- RoHS Compliant

Applications:

Range Finding
 Sensors
 OTDRs

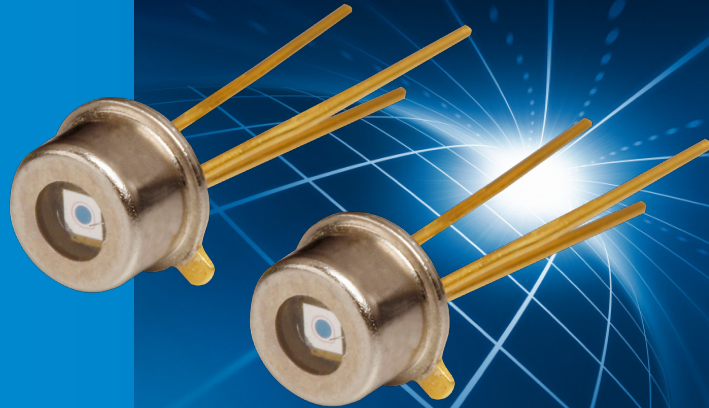

The LAPD 1550-200R is a 200um InGaAs APD housed in a hermetic 3 pin TO46 Package. The low noise and high sensitivity of the LAPD 1550-200R APD make it ideal for use in range finding, sensors, OTDRs and any other low light level detection application.

Characteristics ($T_{amb} = 25^{\circ}\text{C}$)

PARAMETERS	SYMBOL	CONDITIONS	Min	Typ	Max	Units
Active Area Diameter	\varnothing			200		μm
Operational Wavelength	λ		800		1700	nm
Peak Responsivity Wavelength	λ_p			1550		nm
Responsivity	R	$\lambda = 1550\text{nm}, M = 1$	0.7	0.75		A/W
Dark Current	I	$M = 10$		20	24	nA
Breakdown Voltage	V_{br}	$I_d > 100 \mu\text{A}$	30	37	40	V
dV / dT	Γ		15	17	19	mV / $^{\circ}\text{C}$
Capacitance	C_T	$f = 1 \text{ MHz}, M > 3$		4		pF
Bandwidth	$f_{3\text{db}}$	$RL = 50\Omega, 3 < M < 10$		200		MHz
Excess Noise Factor	NEF	$M = 10$		3.5		
Noise Equivalent Power	NEP	$\lambda = 1550\text{nm}, M = 10$		4.97×10^{-14}		W / $\text{Hz}^{0.5}$
Absolute Max Reverse Current	I_r				3	mA
Max Forward Current	I_f				5	mA
Operating Temperature Range	T_{op}		-40		85	$^{\circ}\text{C}$
Storage Temperature	T_{stg}	Non operating	-40		85	$^{\circ}\text{C}$

Outline Drawing

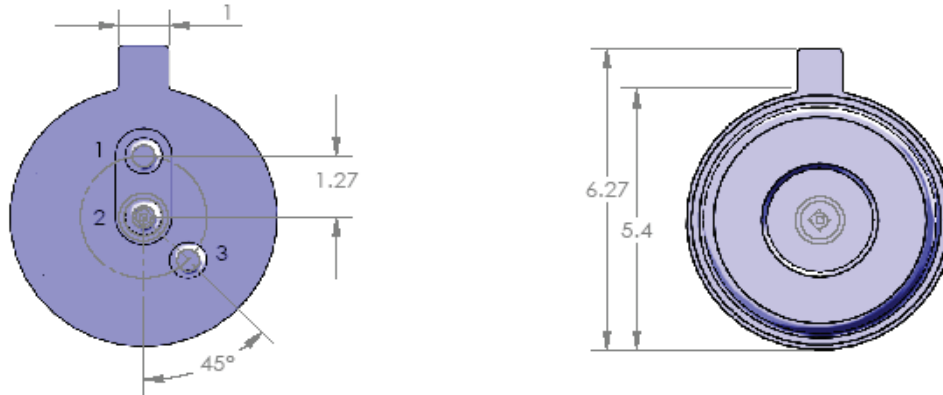

PINOUT TABLE	
PIN No.	Description
1	Anode
2	Cathode
3	Ground

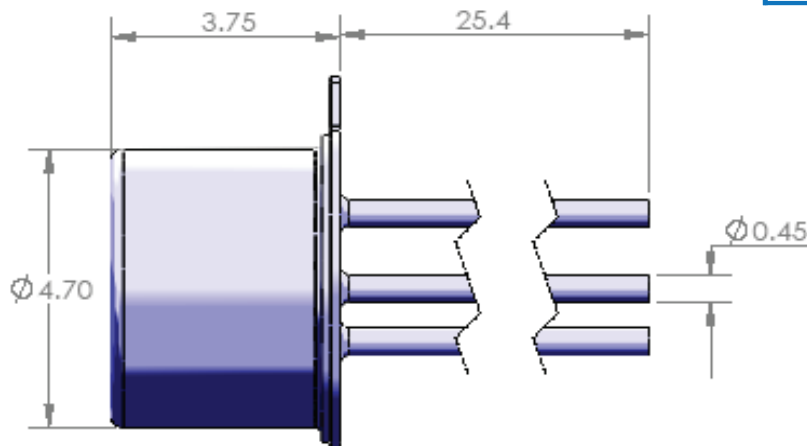

Dimensions: mm

Ordering Information

Products can be ordered directly from OSI Laser Diode, Inc. or its representatives.
For a complete listing of representatives, visit our website at
www.laserdiode.com

When ordering, refer to model number **LAPD 1550-200R**

Personal Hazard and Handling Precautions:

ESD precautions apply.

Warranty:

Please refer to your product purchase agreement for complete details or check with your OSI Laser Diode sales representative.

Notice:

OSI Laser Diode, Inc. reserves the right to make changes to the products or information contained herein without notice.
No liability is assumed as a result of their use or application.