

EPIGAP Optronic GmbH

Koepenicker Str. 325b
D-12555 Berlin
Fon: +49 (0)30 657637 60
Fax: +49 (0)30 657637 70
sales@epigap-optronic.de



Data Sheet

Page 1 of 3

Si photodiode

EOPD-940-0-15

Rev. 01, 2016

Spectral range	Type	Case
Blue ... infrared	Si	TO-5, glass window cap

Square 15 mm² active area photodiode in a hermetic TO-5 metal can. It is well suited for applications requiring high sensitivity (green/blue) as well as visible-near IR applications.

Features:

- > Wide Dynamic Range
- > High Shunt Resistance
- > Ultra Low Noise
- > Blue Enhanced

Applications:

- > Colorimeters
- > Photometers
- > Spectroscopy Equipment
- > Fluorescence

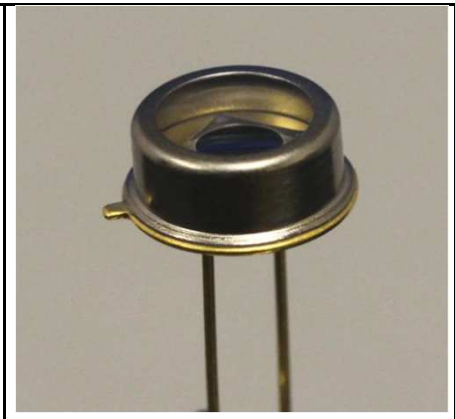

Absolute maximum ratings

Parameters	Symbol	Rating	Unit
Reverse voltage	V_R	50	V
Operating temperature range	T_{OPR}	-40...+100	°C
Storage temperature range	T_{STG}	-55...+125	°C
Lead soldering temperature*	T_{LS}	260	°C

*Time 5 sec max, position: up to 3 mm from the body



Electro-optical characteristics:

T_{amb} = 25°C, unless otherwise specified

Parameters	Symbol	Min	Typ	Max	Unit	Test conditions
Photocurrent @ 1300 nm**	I_{PH}			10	mA	$V_R=10\text{ V}$, $E_o=5\text{ mW/cm}^2$
Dark current	I_D			1	nA	$V_R=10\text{ V}$
Sensitivity range	λ	400		1100	nm	
Peak sensitivity WL	λ_P		940		nm	
Responsivity	S_λ		0.22		A/W	$V_R=0\text{ V}$, $\lambda=410\text{ nm}$
Responsivity	S_λ		0.60		A/W	$V_R=0\text{ V}$, $\lambda=940\text{ nm}$
Response time	t_R		70		ns	$V_R=10\text{ V}$, $R_L=50\ \Omega$, $\lambda=940\text{ nm}$
Junction capacitance	C_j		130	190	pF	$V_R=0\text{ V}$, 1 MHz
Junction capacitance	C_j		50	60	pF	$V_R=5\text{ V}$, 1 MHz
Shunt resistance	R_S	150	200		MΩ	$V_R=10\text{ mV}$

**Standard Tungsten Lamp, Color Temperature=2870 K

We reserve the right to make changes to improve technical design and may do so without further notice. Parameters can vary in different applications. All operating parameters must be validated for each customer application by the customer.

EPIGAP Optronik GmbH

Koepenicker Str. 325b
D-12555 Berlin
Fon: +49 (0)30 657637 60
Fax: +49 (0)30 657637 70
sales@epigap-optronic.de



Data Sheet

Si photodiode

EOPD-940-0-15

Page 2 of 3

Rev. 01, 2016

TO-5 Package Dimensions (2 Pin)

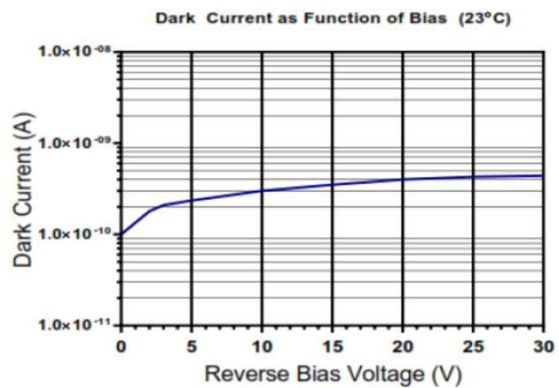
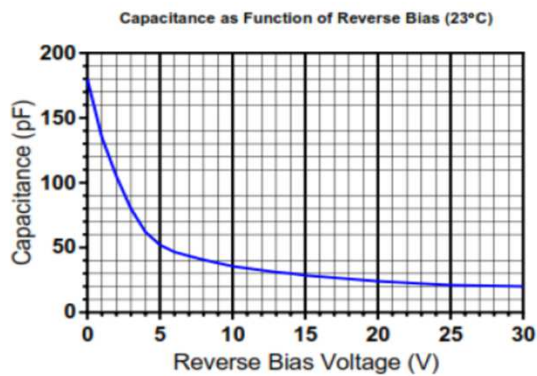
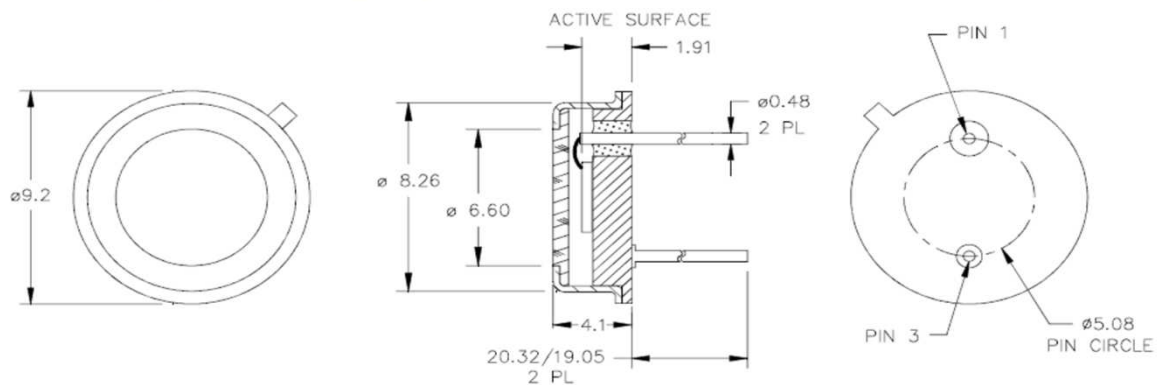

We reserve the right to make changes to improve technical design and may do so without further notice. Parameters can vary in different applications. All operating parameters must be validated for each customer application by the customer.

EPIGAP Optronik GmbH

Koepenicker Str. 325b
D-12555 Berlin
Fon: +49 (0)30 657637 60
Fax: +49 (0)30 657637 70
sales@epigap-optronic.de



Data Sheet

Si photodiode

EOPD-940-0-15

Page 2 of 3
Rev. 01, 2016

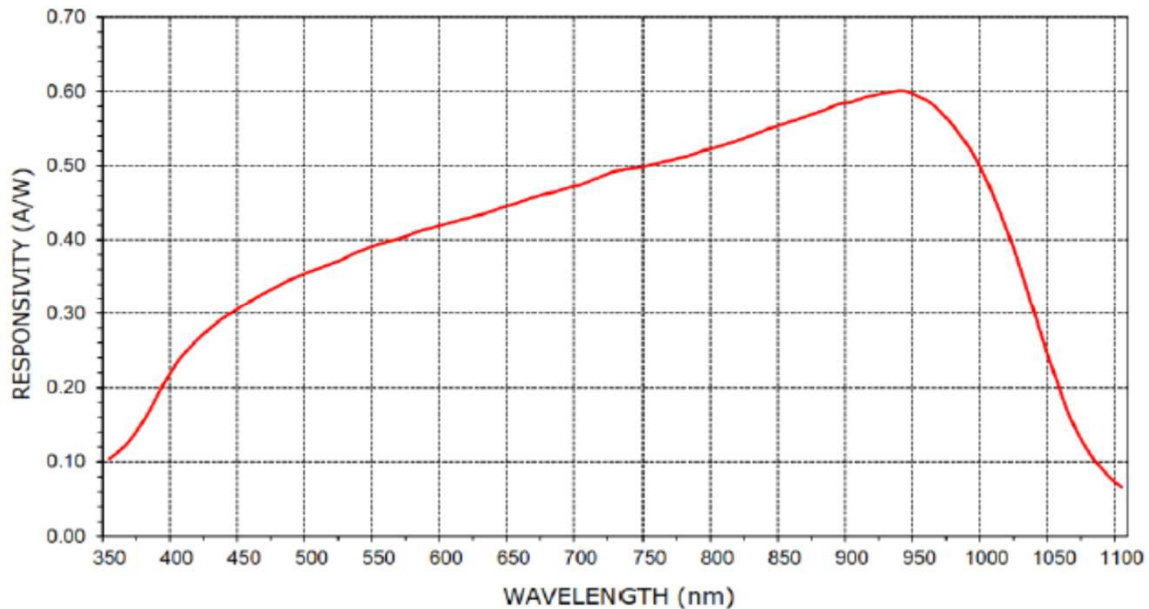
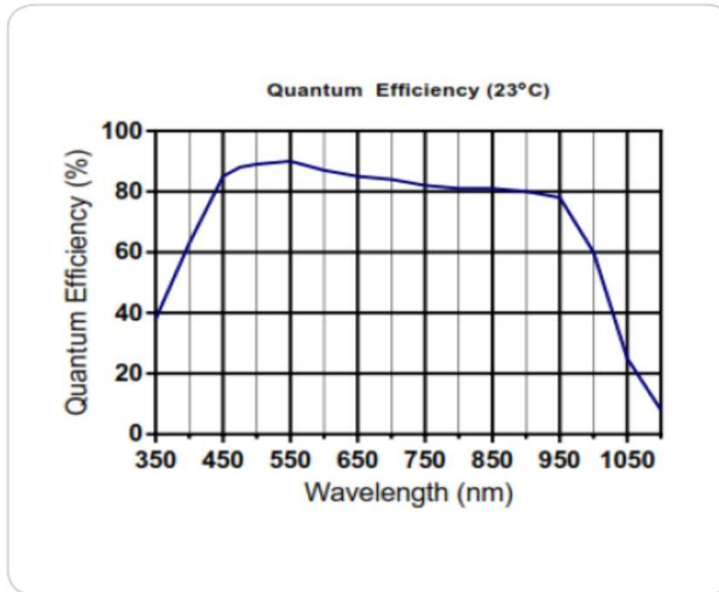

Art. No. 143 047



We reserve the right to make changes to improve technical design and may do so without further notice. Parameters can vary in different applications. All operating parameters must be validated for each customer application by the customer.