

Data Sheet

Infrared SMD LED

EOLS-1650-843

Radiation	Type	Case
infrared	InGaAsP	SMD 3216 (1206)

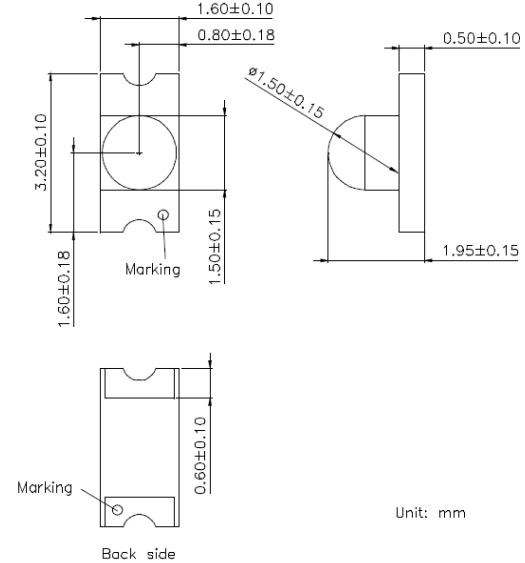

Unit: mm



Description:

- Size 1206: 3.2 (L) x 1.6 (W) x 1.95 (H) mm
- Circuit substrate: glass laminated epoxy
- Devices are RoHS conform
- Lead free solderable, soldering pads: gold plated
- Marking at cathode

Maximum Ratings

T_{amb} = 25°C, unless otherwise specified

Parameter	Test Conditions	Symbol	Value	Unit
Peak forward current	t _p ≤ 100 μs τ = 1:10	I _{FP}	100	mA
Continuous forward current		I _F	50	mA
Reverse voltage		V _R	5	V
Operating temperature range		T _{amb}	-40 to +85	°C
Storage temperature range		T _{stg}	-55 to +85	°C
Thermal resistance		R _{thJA}	450	K/W

Optical and Electrical Characteristics

T_{amb} = 25°C, unless otherwise specified



Parameter	Symbol	Conditions	Min	Typ	Max	Unit
Forward voltage	V _F	I _F = 50 mA		0.75	1.3	V
Reverse current	I _R	V _R = 5 V			100	μA
Radiant power	Φ _e	I _F = 50 mA		3		mW
Peak wavelength	λ _p	I _F = 50 mA	1600	1650	1700	nm
FWHM	Δλ _{0.5}	I _F = 50 mA		130		nm
Viewing angle	φ	I _F = 50 mA		50		deg
Temperature coefficient	TCΦ _e	I _F = 20 mA		-0.4		%/K
Temperature coefficient	TCλ _p	I _F = 20 mA		+0.5		nm/K

We reserve the right to make changes to improve technical design and may do so without further notice. Parameters can vary in different applications. All operating parameters must be validated for each customer application by the customer.

EPIGAP Optronik GmbH

Koepenicker Str. 325
D-12555 Berlin
Fon: +49 (0)30 657637 60
Fax: +49 (0)30 657637 70
sales@epigap-optronic.de



Data Sheet

page 2 of 5

Infrared SMD LED

EOLS-1650-843

Rev. 05, 2017

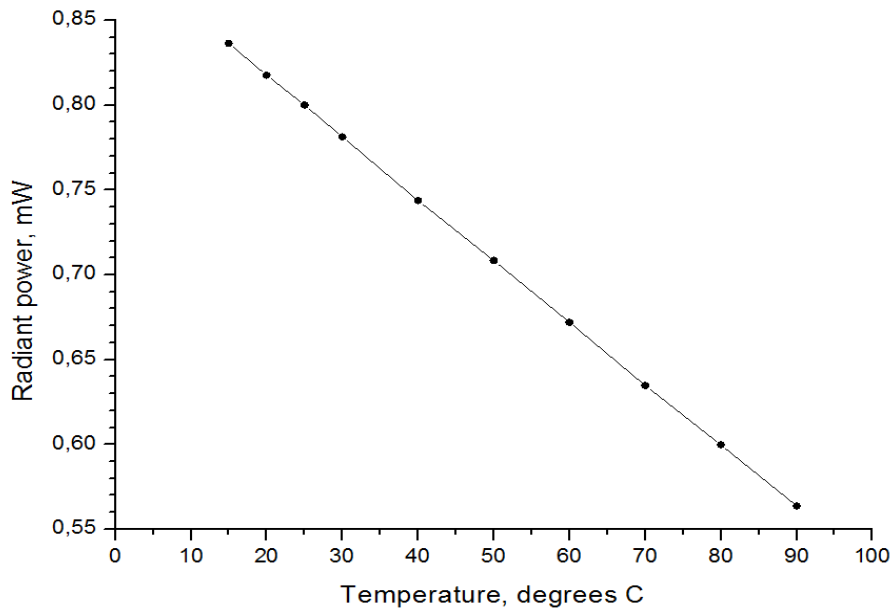

Radiant power vs. temperature @ 20 mA

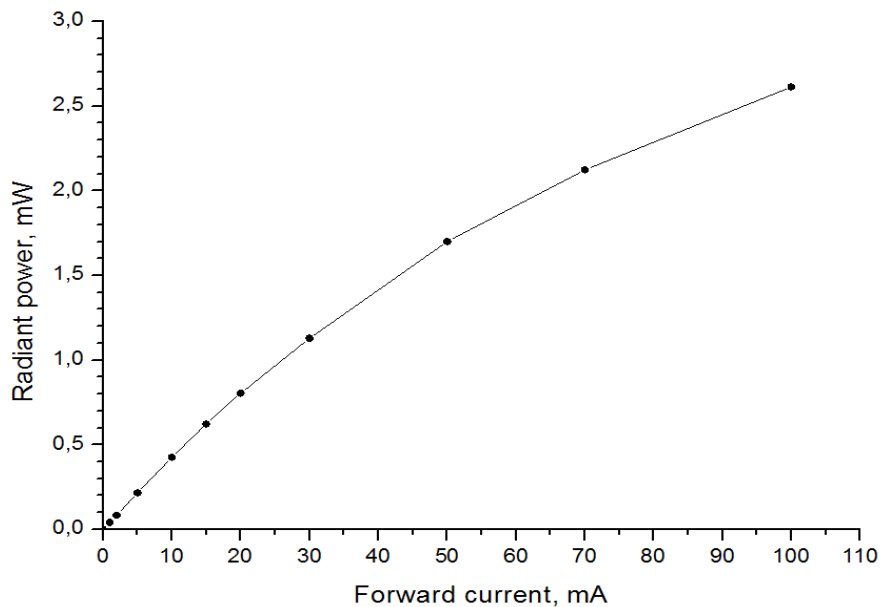

Radiant power vs. forward current



We reserve the right to make changes to improve technical design and may do so without further notice. Parameters can vary in different applications. All operating parameters must be validated for each customer application by the customer.

EPIGAP Optronic GmbH

Koepenicker Str. 325
D-12555 Berlin
Fon: +49 (0)30 657637 60
Fax: +49 (0)30 657637 70
sales@epigap-optronic.de



Data Sheet

page 3 of 5

Infrared SMD LED

EOLS-1650-843

Rev. 05, 2017

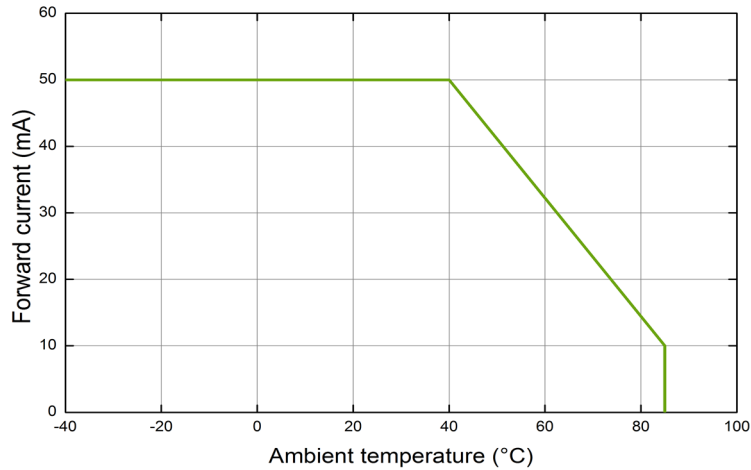

Max. forward current vs. ambient temperature

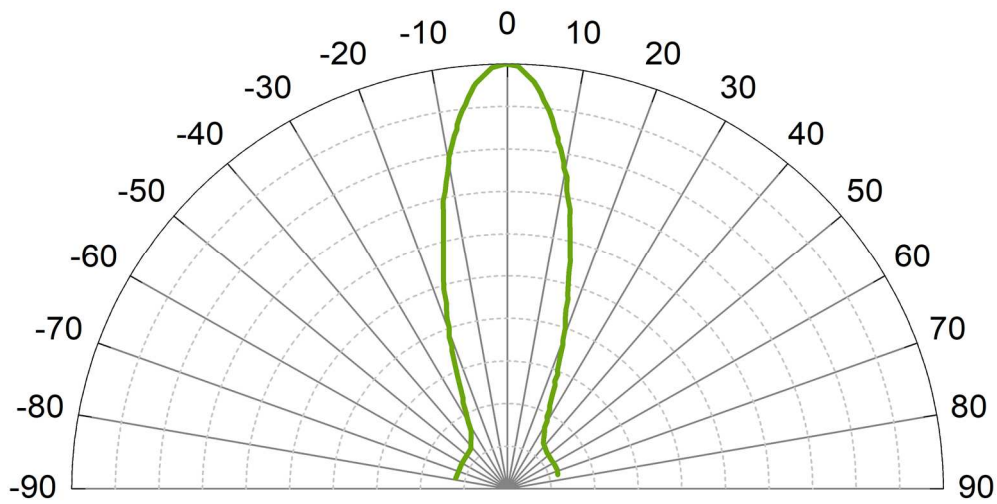

Radiation pattern



We reserve the right to make changes to improve technical design and may do so without further notice. Parameters can vary in different applications. All operating parameters must be validated for each customer application by the customer.

EPIGAP Optronic GmbH

Koepenicker Str. 325
D-12555 Berlin
Fon: +49 (0)30 657637 60
Fax: +49 (0)30 657637 70
sales@epigap-optronic.de



Data Sheet

page 4 of 5

Infrared SMD LED

EOLS-1650-843

Rev. 05, 2017

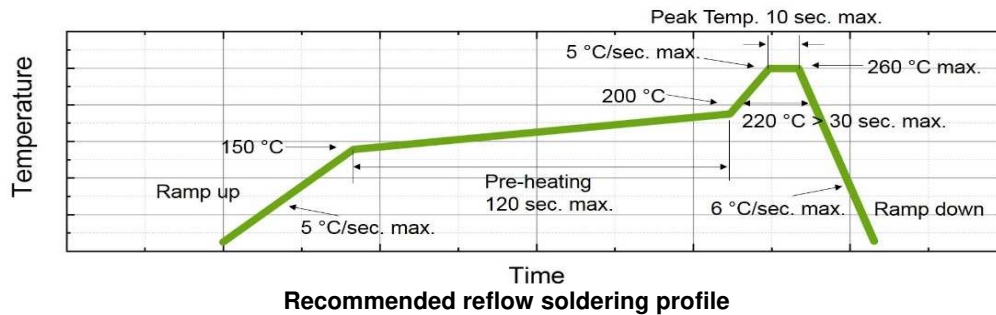

Recommended reflow soldering profile

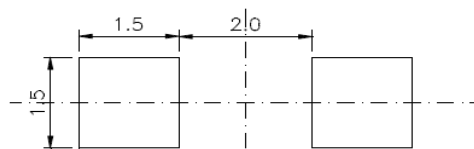

Pad TU

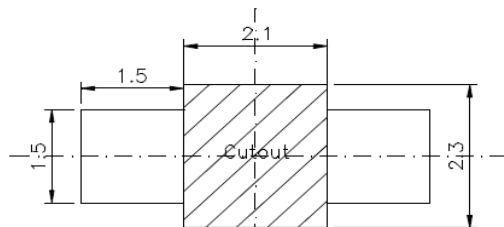

Pad TD

Recommended soldering patterns

Manual soldering:

max power of iron 25 W / 3 s / 300°C



We reserve the right to make changes to improve technical design and may do so without further notice. Parameters can vary in different applications. All operating parameters must be validated for each customer application by the customer.

EPIGAP Optronik GmbH

Koepenicker Str. 325
D-12555 Berlin
Fon: +49 (0)30 657637 60
Fax: +49 (0)30 657637 70
sales@epigap-optronic.de



Data Sheet

Infrared SMD LED

EOLS-1650-843

page 5 of 5
Rev. 04, 2017

Measured according to CIE 127. All SMD LEDs are 100% measured and selected on full automated equipment with an accuracy of $\pm 11\%$.

Tape and Reel packing

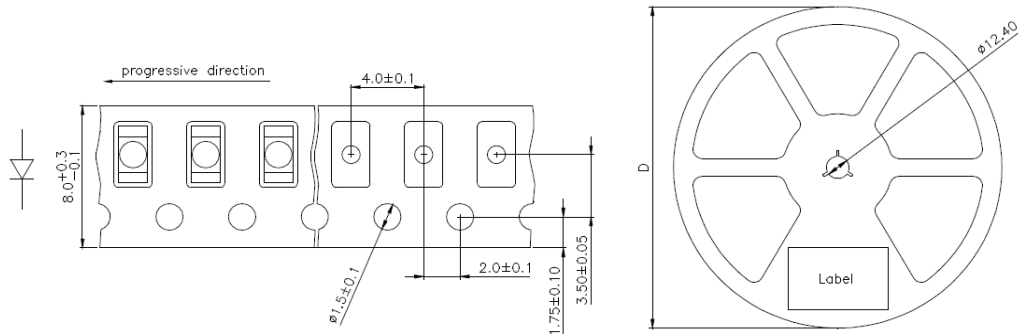

D	Parts / reel
180 mm	2000
330 mm	8000

Packing: The reel is seaLED in special plastic bag with integrate ESD protection (MIL - STD 81705) including a silica dry-pack

Art. No. 133 137



We reserve the right to make changes to improve technical design and may do so without further notice. Parameters can vary in different applications. All operating parameters must be validated for each customer application by the customer.