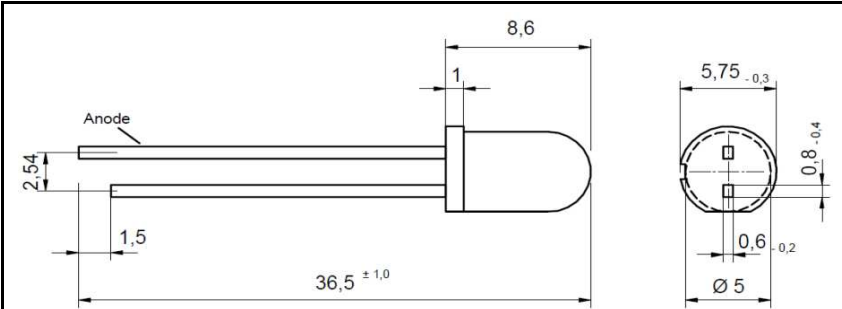

Data sheet

Infrared LED

EOLD-1050-525

Radiation	Type	Case
Infrared	InGaAs, MQW	5 mm plastic lens

Description:	
	
High-power, high-speed infrared LED in standard 5 mm package, housing without standoff leads for optical communications, safety equipment and automation All dimensions in mm	

Maximum Ratings

T_{amb}= 25°C, unless otherwise specified

Parameter	Test Conditions	Symbol	Value	Unit
Forward current		I _F	100	mA
Peak forward current	t _p ≤ 50 μs, t _p / T = 1/2	I _{FM}	200	mA
Power dissipation		P _D	150	mW
Operating temperature range		T _{amb}	-20 to +80	°C
Storage temperature range		T _{stg}	-55 to +85	°C
Lead soldering temperature	t < 5 s, 3 mm from case	T _{slg}	260	°C

Optical and Electrical Characteristics

T_{amb}= 25°C, unless otherwise specified

Parameter	Symbol	Conditions	Min	Typ	Max	Unit
Forward voltage	V _F	I _F = 20 mA		1.15	1.4	V
Forward voltage	V _F	I _F = 100 mA		1.25	1.5	V
Reverse voltage	V _R	I _R = 10 μA	5			V
Radiant power	Φ _e	I _F = 20 mA		7		mW
Radiant power	Φ _e	I _F = 50 mA		17		mW
Radiant power	Φ _e	I _F = 100 mA		30		mW
Peak wavelength	λ _p	I _F = 20 mA	1030	1050	1070	nm
Peak wavelength	λ _p	I _F = 100 mA		1050	1080	nm
FWHM	Δλ _{0,5}	I _F = 20 mA		40		nm
FWHM	Δλ _{0,5}	I _F = 50 mA		50		nm
FWHM	Δλ _{0,5}	I _F = 100 mA		60		nm
Viewing angle	φ	I _F = 20 mA		20		deg.
Switching time	t _r , t _f	I _F = 20 mA		20		ns



EPIGAP Optronik GmbH

Koepenicker Str. 325b
D-12555 Berlin
Fon: +49 (0)30 657637 60
Fax: +49 (0)30 657637 70
sales@epigap-optronic.de



Data sheet

Page 2 of 2

Infrared LED

EOLD-1050-525

Rev. 03, 2017

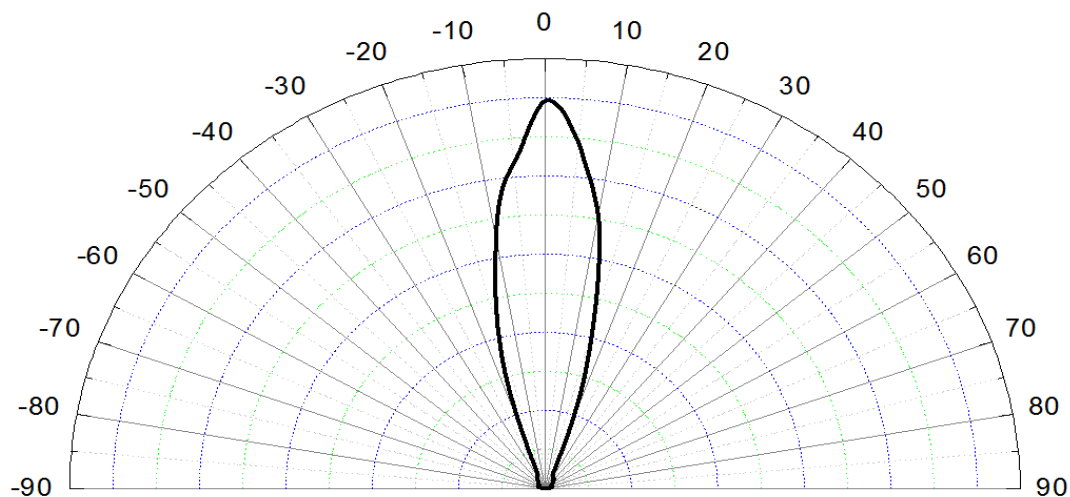

Typical radiation pattern

Art. No. 430 060



We reserve the right to make changes to improve technical design and may do so without further notice. Parameters can vary in different applications. All operating parameters must be validated for each customer application by the customer.