

EPIGAP Optronik GmbH

Koepenicker Str. 325b
 D-12555 Berlin
 Fon: +49 (0)30 657637 60
 Fax: +49 (0)30 657637 70
 sales@epigap-optronic.de



Data Sheet

LED Chip Infrared

EOLC-850-17

Rev. 03, 2017

Radiation	Type	Electrodes
Infrared	AlGaAs/AlGaAs, DDH	P (anode) up

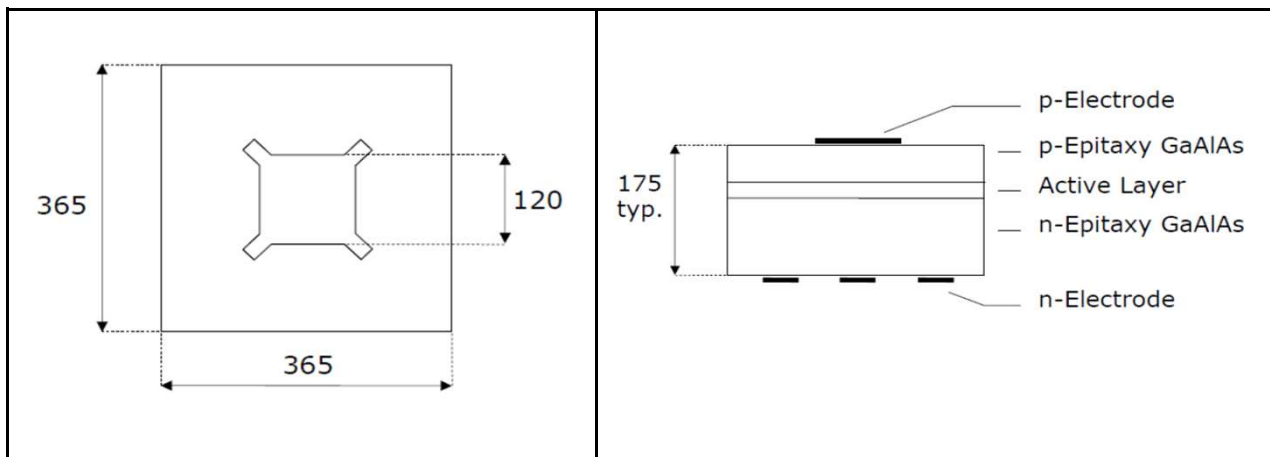

Optical and Electrical Characteristics

$T_{amb} = 25^{\circ}\text{C}$, unless otherwise specified

Parameter	Test cond.	Symbol	Min	Typ	Max	Unit
Forward voltage	$I_F = 20 \text{ mA}$	V_F		1.4	1.6	V
Reverse voltage	$I_R = 100 \mu\text{A}$	V_R	5			V
Radiant power*	$I_F = 20 \text{ mA}$	Φ_e	4.5	5.5		mW
Radiant power**	$I_F = 20 \text{ mA}$	Φ_e		11		mW
Peak wavelength	$I_F = 20 \text{ mA}$	λ_p	840	850	860	nm
FWHM	$I_F = 20 \text{ mA}$	$\Delta\lambda_{0.5}$		40		nm
Switching time	$I_F = 20 \text{ mA}$	t_r, t_f		17; 8		ns

*Measured on bare chip on TO-18 header

**Measured on epoxy covered chip on TO-18 header

Packing

Chips on adhesive film with wire-bond side top

Art. No. 113 018



We reserve the right to make changes to improve technical design and may do so without further notice. Parameters can vary in different applications. All operating parameters must be validated for each customer application by the customer.