

# EPIGAP Optronik GmbH

Koepenicker Str. 325b, Haus 41  
 D-12555 Berlin  
 Fon: +49 (0)30 657637 60  
 Fax: +49 (0)30 657637 70  
 sales@epigap-optronic.de



## Product Data Sheet

### LED Chip Infra Red

### EOLC-700-27

Rev. 01 aus 2011

Radiation	Type	Electrodes
Infra Red	DDW	N (cathode) up

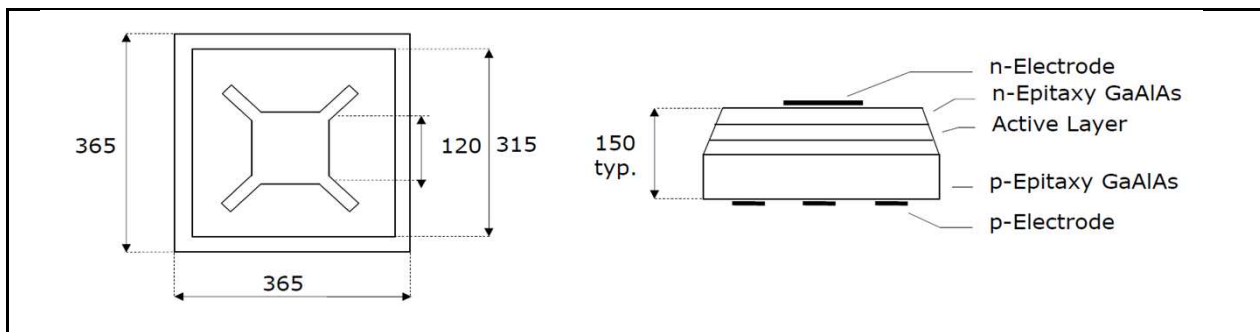

### Optical and Electrical Characteristics

T<sub>amb</sub> = 25°C, unless otherwise specified

Parameter	Test cond.	Symbol	Min	Typ	Max	Unit
Forward voltage	I <sub>F</sub> =20mA	V <sub>F</sub>		1.90	2.3	V
Reverse voltage	I <sub>R</sub> =100μA	V <sub>R</sub>	5			V
Output Power <sup>1</sup>	I <sub>F</sub> =20mA	Φ <sub>e</sub>	1.5	2.5		mW
Switching time	I <sub>F</sub> =20mA	t <sub>r</sub> , t <sub>f</sub>		50/35		ns
Peak wavelength	I <sub>F</sub> =20mA	λ <sub>p</sub>	695	700	705	nm
Spectral bandwidth at 50%	I <sub>F</sub> =20mA	Δλ <sub>0.5</sub>		23		nm

<sup>1</sup> Measured on bare chip on TO18 header

### Labeling

Type	Lot N°	Φ <sub>e</sub> (typ) [mW]	V <sub>F</sub> (typ) [V]	Quantity
EOLC-700-27				

### Packing

Chips on adhesive film with wire-bond side top

We reserve the right to make changes to improve technical design and may do so without further notice. Parameters can vary in different applications. All operating parameters must be validated for each customer application by the customer.