

EPIGAP Optronic GmbH

Koepenicker Str. 325b, Haus 41
 D-12555 Berlin
 Fon: +49 (0)30 657637 60
 Fax: +49 (0)30 657637 70
 sales@epigap-optronic.de

customized optoelectronics



Product Data Sheet

LED Chip VIS

EOLC-610-14

Rev. 01 aus 2011

Radiation	Type	Electrodes
Orange	Standard	P (anode) up

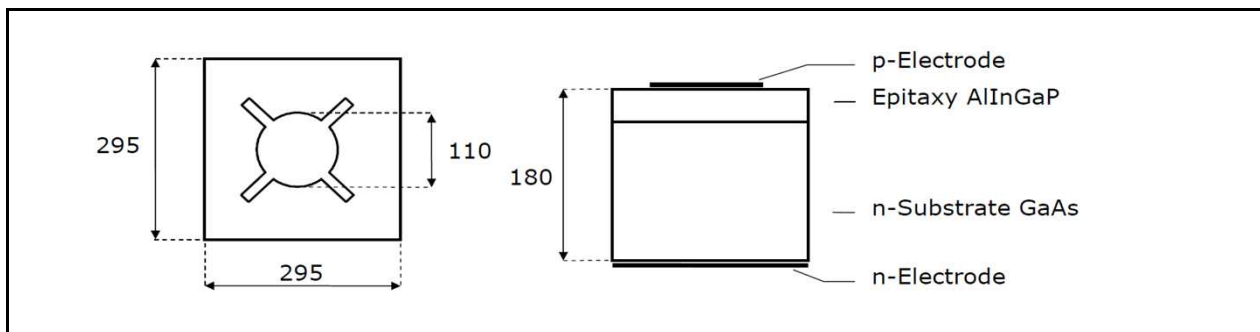

Optical and Electrical Characteristics

T_{amb} = 25°C, unless otherwise specified

Parameter	Test cond.	Symbol	Min	Typ	Max	Unit
Forward voltage	I _F =20mA	V _F		1.95	2.3	V
Reverse current	V _r = 5V	I _R			10	μA
Luminous intensity ¹	I _F =20mA	I _v	150	200		mcd
Peak wavelength	I _F =20mA	λ _p	605	610	615	nm
Spectral bandwidth at 50%	I _F =20mA	Δλ _{0,5}		16		nm

¹Measured on EPIGAP gold plate

Labeling

Type	Lot N°	Φ _e (typ) [mW]	V _F (typ) [V]	Qty.
EOLC-610-14				

Packing

Chips on adhesive film with wire bond side up

We reserve the right to make changes to improve technical design and may do so without further notice. Parameters can vary in different applications. All operating parameters must be validated for each customer application by the customer.