

High Speed Silicon Photodiodes

High Speed Silicon Series

OSI Optoelectronics High Speed Silicon series are small area devices optimized for fast response time or High bandwidth applications. The BPX-65 complements the rest of the high speed group with an industry standard.

The spectral range for these devices goes from 350 nm to 1100 nm. The responsivity and response time are optimized such that the HR series exhibit a peak responsivity of 0.50 A/W at 800 nm and typical response times of a few hundred pico seconds at -5V.

Note that for all high-speed photodetectors, a reverse bias is required to achieve the fastest response times. However, the reverse bias should be limited to maximum reverse voltage specified to avoid damage to the detector. Output signals can be measured directly with an oscilloscope or coupled to high frequency amplifiers as shown in figure 10 of the Photodiode Characteristics section of the catalog. All parts in the High-Speed silicon series are available with a flat window or ball lens (L).

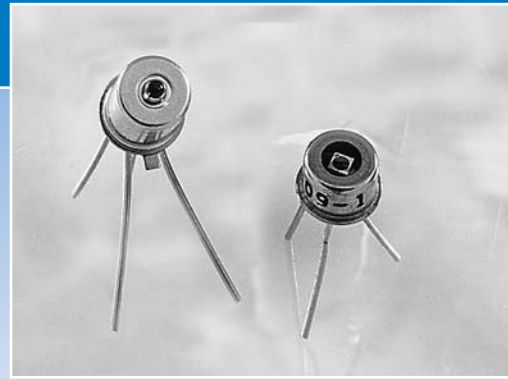

APPLICATIONS

- Video Systems
- Computers and Peripherals
- Industrial Control
- Guidance Systems
- Laser Monitoring

FEATURES

- Low Dark Current
- Low Capacitance
- TO-46 Package
- w/Lensed Cap
- Sub ns Response

Typical Capacitance vs. Reverse Bias

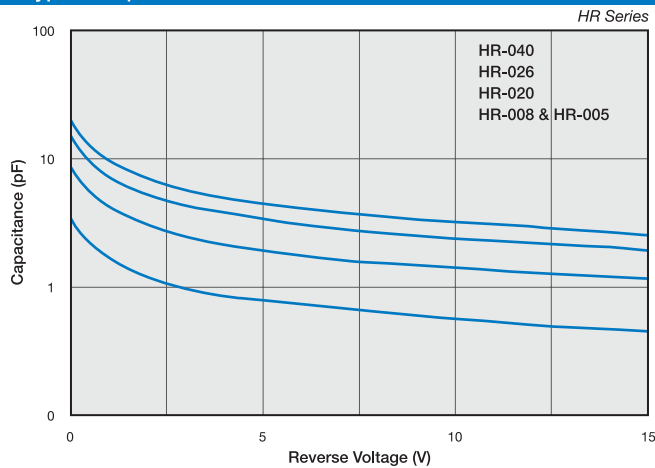

Typical Frequency Response vs. Reverse Bias

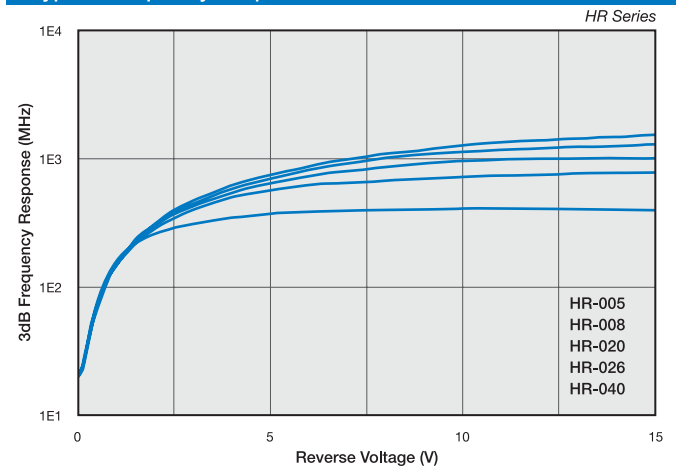

Typical Capacitance vs. Reverse Bias

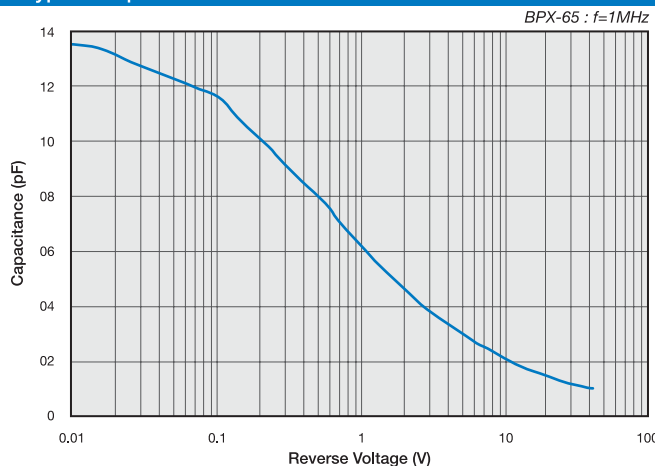

Typical Frequency Response vs. Reverse Bias

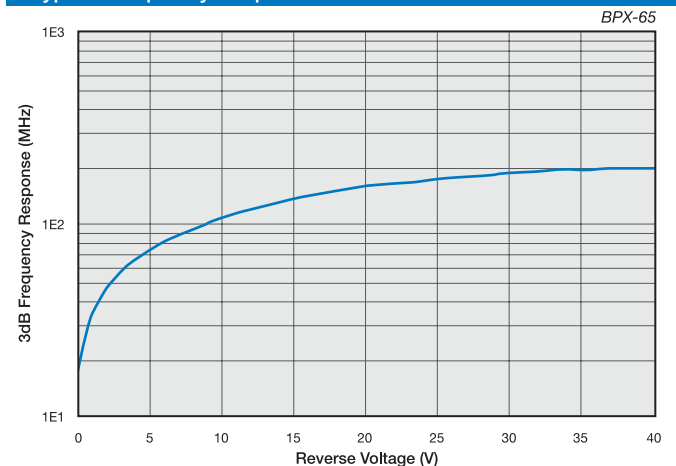

High Speed Silicon Series

Typical Electro-Optical Specifications at $T_A=23^{\circ}\text{C}$

Model Number	Active Area		Peak Wavelength (nm)	Responsivity (A/W)		Capacitance (pF) ‡	Dark Current (nA) ‡		NEP (W/√Hz)	Reverse Voltage (V)	Rise Time § (ns) ‡	Temp.** Range (°C)		Package Style ¶
	Area (mm ²)	Dimensions (mm)		830 nm			830 nm	830 nm			50 Ω	Operating	Storage	
				min.	typ.									

High Responsivity Series ($V_{BIAS}=-5\text{ V}$)

Model Number	Area (mm ²)	Dimensions (mm)	Peak Wavelength (nm)	Responsivity (A/W) min.	Responsivity (A/W) typ.	Capacitance (pF) typ.	Dark Current (nA) typ.	Dark Current (nA) max.	NEP (W/√Hz) typ.	Reverse Voltage (V) max.	Rise Time (ns) typ.	Temp. Range (°C) Operating	Temp. Range (°C) Storage	Package Style ¶					
PIN-HR005 PIN-HR005L*	0.01	0.127 φ	800	0.45*	0.50*	0.8	0.03	0.8	5.0 e-15	15	0.60	-25 ~ +85	-40 ~ +100	9 / TO-18 16 / TO-18 (L - Ball Lens Cap)					
PIN-HR008 PIN-HR008L*	0.04	0.203 sq													0.8	0.03	0.8	5.0 e-15	0.60
PIN-HR020 PIN-HR020L*	0.02	0.508 φ													1.8	0.06	1.0	7.1 e-15	0.80
PIN-HR026 PIN-HR026L*	0.34	0.660 φ													2.6	0.1	1.5	1.0 e-14	0.90
PIN-HR040 PIN-HR040L*	0.77	0.991 φ													4.9	0.3	2.0	1.9 e-14	1.0

BPX-65 ($V_{BIAS}=-20\text{ V}$)

Model Number	Area (mm ²)	Dimensions (mm)	Peak Wavelength (nm)	Responsivity (A/W) min.	Responsivity (A/W) typ.	Capacitance (pF) typ.	Dark Current (nA) typ.	Dark Current (nA) max.	NEP (W/√Hz) typ.	Reverse Voltage (V) max.	Rise Time (ns) typ.	Temp. Range (°C) Operating	Temp. Range (°C) Storage	Package Style ¶
BPX-65	1.0	1.0 sq	900	0.45	0.5	3.0	0.5	5.0	2.3 e-14	50	2.0	-25 ~ +85	-40 ~ +100	7 / TO-18

Model Number	Active Area		Peak Wavelength (nm)	Responsivity (A/W)		Capacitance (pF) ‡	Dark Current (nA) ‡		NEP (W/√Hz)	Reverse Voltage (V)	Rise Time § (ns) ‡	Temp.** Range (°C)		Package Style ¶
	Area (mm ²)	Dimensions (mm)		900 nm			900 nm	820 nm			Operating	Storage		
				min.	typ.								typ.	

BPX-65R ($V_{BIAS}=-20\text{ V}$)

Model Number	Area (mm ²)	Dimensions (mm)	Peak Wavelength (nm)	Responsivity (A/W) min.	Responsivity (A/W) typ.	Capacitance (pF) typ.	Dark Current (nA) typ.	Dark Current (nA) max.	NEP (W/√Hz) typ.	Reverse Voltage (V) max.	Rise Time (ns) typ.	Temp. Range (°C) Operating	Temp. Range (°C) Storage	Package Style ¶
BPX-65R	1.0	1.0 sq	850	0.52	0.55	3.5	1.0	5.0	3.3 e-14	30	3.5	-40 ~ +80	-55 ~ +100	4 / TO-18

¶ For mechanical drawing, please refer to pages 58 thru 69.

* Responsivities are measured for Flat window devices. L- Refers to devices with a Ball-type lens cap. Chip centering is within +/- 0.005" wrt OD of the Header.

** Non-Condensing temperature and Storage Range, Non-Condensing Environment. Cathode on BPX-65R is connected to the case.

Typical Spectral Response

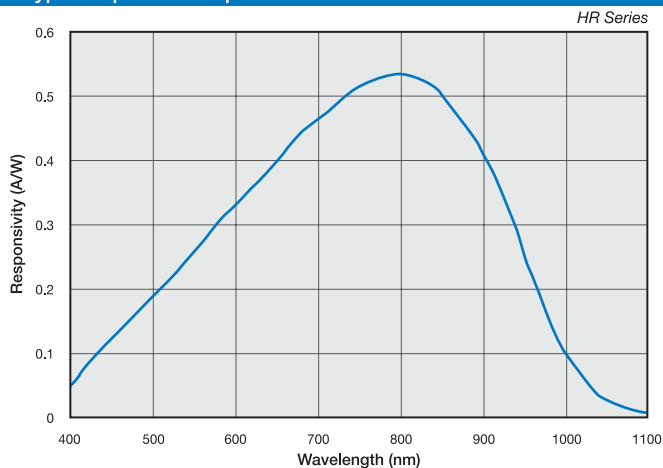

Typical Spectral Response

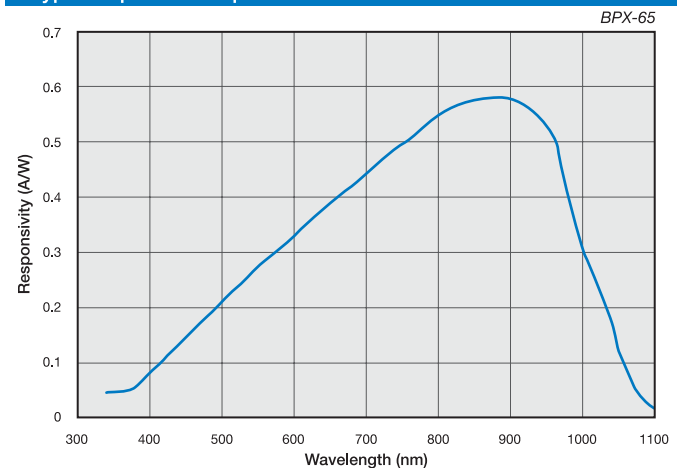

■ Photodiode Care and Handling Instructions

AVOID DIRECT LIGHT

Since the spectral response of silicon photodiode includes the visible light region, care must be taken to avoid photodiode exposure to high ambient light levels, particularly from tungsten sources or sunlight. During shipment from OSI Optoelectronics, your photodiodes are packaged in opaque, padded containers to avoid ambient light exposure and damage due to shock from dropping or jarring.

AVOID SHARP PHYSICAL SHOCK

Photodiodes can be rendered inoperable if dropped or sharply jarred. The wire bonds are delicate and can become separated from the photodiode's bonding pads when the detector is dropped or otherwise receives a sharp physical blow.

CLEAN WINDOWS WITH OPTICAL GRADE CLOTH / TISSUE

Most windows on OSI Optoelectronics photodiodes are either silicon or quartz. They should be cleaned with isopropyl alcohol and a soft (optical grade) pad.

OBSERVE STORAGE TEMPERATURES AND HUMIDITY LEVELS

Photodiode exposure to extreme high or low storage temperatures can affect the subsequent performance of a silicon photodiode. Storage temperature guidelines are presented in the photodiode performance specifications of this catalog. Please maintain a non-condensing environment for optimum performance and lifetime.

OBSERVE ELECTROSTATIC DISCHARGE (ESD) PRECAUTIONS

OSI Optoelectronics photodiodes, especially with IC devices (e.g. Photops) are considered ESD sensitive. The photodiodes are shipped in ESD protective packaging. When unpacking and using these products, anti-ESD precautions should be observed.

DO NOT EXPOSE PHOTODIODES TO HARSH CHEMICALS

Photodiode packages and/or operation may be impaired if exposed to CHLOROTHENE, THINNER, ACETONE, or TRICHLOROETHYLENE.

INSTALL WITH CARE

Most photodiodes in this catalog are provided with wire or pin leads for installation in circuit boards or sockets. Observe the soldering temperatures and conditions specified below:

Soldering Iron:	Soldering 30 W or less Temperature at tip of iron 300°C or lower.
Dip Soldering:	Bath Temperature: 260±5°C. Immersion Time: within 5 Sec. Soldering Time: within 3 Sec.
Vapor Phase Soldering:	DO NOT USE
Reflow Soldering:	DO NOT USE

Photodiodes in plastic packages should be given special care. Clear plastic packages are more sensitive to environmental stress than those of black plastic. Storing devices in high humidity can present problems when soldering. Since the rapid heating during soldering stresses the wire bonds and can cause wire to bonding pad separation, it is recommended that devices in plastic packages to be baked for 24 hours at 85°C.

The leads on the photodiode **SHOULD NOT BE FORMED**. If your application requires lead spacing modification, please contact OSI Optoelectronics Applications group at (310)978-0516 before forming a product's leads. Product warranties could be voided.

1. Parameter Definitions:

A = Distance from top of chip to top of glass.

a = Photodiode Anode.

B = Distance from top of glass to bottom of case.

c = Photodiode Cathode

(Note: cathode is common to case in metal package products unless otherwise noted).

W = Window Diameter.

F.O.V. = Field of View (see definition below).

2. Dimensions are in inches (1 inch = 25.4 mm).

3. Pin diameters are 0.018 ± 0.002" unless otherwise specified.

4. Tolerances (unless otherwise noted)

General: 0.XX ±0.01"

0.XXX ±0.005"

Chip Centering: ±0.010"

Dimension 'A': ±0.015"

5. Windows

All '**UV**' Enhanced products are provided with QUARTZ glass windows, 0.027 ± 0.002" thick.

All '**XUV**' products are provided with removable windows.

All '**DLS**' PSD products are provided with A/R coated glass windows.

All '**FIL**' photoconductive and photovoltaic products are epoxy filled instead of glass windows.

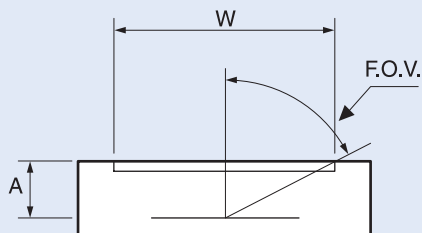

$$F.O.V. = \tan^{-1} \left(\frac{W}{2A} \right)$$



For Further Assistance
Please Call One of Our Experienced
Sales and Applications Engineers

310-978-0516



- Or -
On the Internet at

www.osioptoelectronics.com

Mechanical Specifications

All units in inches. Pinouts are bottom view.

1 TO-18	2 TO-5	3 TO-8																																		
<p>Products:</p> <p>PIN-020A PIN-040A PIN-040-DP/SB</p> <p>Pin Circle Dia.=0.100</p> <table border="1"> <thead> <tr> <th>P/N</th> <th>A</th> <th>B</th> <th>W</th> </tr> </thead> <tbody> <tr> <td>PIN-020A</td> <td>0.075</td> <td>0.200</td> <td>0.155</td> </tr> <tr> <td>PIN-040A</td> <td>0.075</td> <td>0.200</td> <td>0.155</td> </tr> </tbody> </table>	P/N	A	B	W	PIN-020A	0.075	0.200	0.155	PIN-040A	0.075	0.200	0.155	<p>Products:</p> <p>PIN-5DI PIN-5DPI PIN-13DI PIN-13DPI PIN-5-YAG CD-25T</p> <p>Pin Circle Dia.=0.200</p> <table border="1"> <thead> <tr> <th>P/N</th> <th>A</th> <th>B</th> <th>W</th> </tr> </thead> <tbody> <tr> <td>All Others</td> <td>0.094</td> <td>0.180</td> <td>0.240</td> </tr> <tr> <td>CD-25T</td> <td>0.050</td> <td>0.130</td> <td>0.23</td> </tr> </tbody> </table>	P/N	A	B	W	All Others	0.094	0.180	0.240	CD-25T	0.050	0.130	0.23	<p>Products:</p> <p>PIN-6DI PIN-6DPI PIN-44DI PIN-44DPI OSD35-0 OSD35-7Q</p> <p>Pin Circle Dia.=0.295</p> <table border="1"> <thead> <tr> <th>P/N</th> <th>A</th> </tr> </thead> <tbody> <tr> <td>PIN-6DI/6DPI</td> <td>0.115</td> </tr> <tr> <td>PIN-44DI/44DPI</td> <td>0.125</td> </tr> <tr> <td>OSD35-0</td> <td>0.130</td> </tr> <tr> <td>OSD35-7Q</td> <td>0.130 Quartz Window</td> </tr> </tbody> </table>	P/N	A	PIN-6DI/6DPI	0.115	PIN-44DI/44DPI	0.125	OSD35-0	0.130	OSD35-7Q	0.130 Quartz Window
P/N	A	B	W																																	
PIN-020A	0.075	0.200	0.155																																	
PIN-040A	0.075	0.200	0.155																																	
P/N	A	B	W																																	
All Others	0.094	0.180	0.240																																	
CD-25T	0.050	0.130	0.23																																	
P/N	A																																			
PIN-6DI/6DPI	0.115																																			
PIN-44DI/44DPI	0.125																																			
OSD35-0	0.130																																			
OSD35-7Q	0.130 Quartz Window																																			
<p>Products:</p> <p>PIN-2DI PIN-2DPI PIN-3CDP PIN-3CDPI BPX-65R</p> <p>Pin Circle Dia.=0.100</p> <table border="1"> <thead> <tr> <th>P/N</th> <th>A</th> <th>B</th> </tr> </thead> <tbody> <tr> <td>BPX-65R</td> <td>0.070</td> <td>0.200</td> </tr> <tr> <td>All Others</td> <td>0.090</td> <td>0.150</td> </tr> </tbody> </table>	P/N	A	B	BPX-65R	0.070	0.200	All Others	0.090	0.150	<p>Products:</p> <p>PIN-5D PIN-5DP PIN-5DP/SB PIN-13D PIN-13DP PIN-005E-550F UV-001 UV-005 UV-005D UV-005E UV-013D UV-013E UV-015 OSD-5-0 OSD15-0 OSD5-5T OSD15-5T OSD5.8-7Q OSD5.8-7U</p> <p>Pin Circle Dia.=0.200</p> <table border="1"> <thead> <tr> <th>P/N</th> <th>A</th> <th>B</th> </tr> </thead> <tbody> <tr> <td>OSD-Prefix Devices</td> <td>0.050</td> <td>0.130</td> </tr> <tr> <td>All Others</td> <td>0.102</td> <td>0.180</td> </tr> </tbody> </table> <p>Quartz Window: OSD5.8-7Q UV Transmissive Window: OSD5.8-7U</p>	P/N	A	B	OSD-Prefix Devices	0.050	0.130	All Others	0.102	0.180	<p>Products:</p> <p>PIN-6D PIN-6DP PIN-44D PIN-44DP UV-020 UV-035D UV-035E UV-035</p> <p>Pin Circle Dia.=0.295</p>																
P/N	A	B																																		
BPX-65R	0.070	0.200																																		
All Others	0.090	0.150																																		
P/N	A	B																																		
OSD-Prefix Devices	0.050	0.130																																		
All Others	0.102	0.180																																		
<p>Products:</p> <p>PIN-3CD PIN-3CDP BPX-65 OSD1-0 OSD1-5T OSD3-5T OSD1.2-7Q OSD1.2-7U</p> <p>Pin Circle Dia.=0.100</p> <table border="1"> <thead> <tr> <th>P/N</th> <th>A</th> <th>B</th> </tr> </thead> <tbody> <tr> <td>PIN-3CD / 3CDP</td> <td>0.087</td> <td>0.146</td> </tr> <tr> <td>BPX-65</td> <td>0.075</td> <td>0.200</td> </tr> <tr> <td>OSD-Prefix Devices</td> <td>0.080</td> <td>0.200</td> </tr> </tbody> </table> <p>Quartz Window: OSD1.2-7Q UV Transmissive Window: OSD1.2-7U</p>	P/N	A	B	PIN-3CD / 3CDP	0.087	0.146	BPX-65	0.075	0.200	OSD-Prefix Devices	0.080	0.200	<p>Products:</p> <p>PIN-125DPL</p> <p>Pin Circle Dia.=0.100</p>	<p>Products:</p> <p>PIN-HR005 PIN-HR008 PIN-HR020 PIN-HR026 PIN-HR040</p> <p>Pin Circle Dia.=0.100</p>																						
P/N	A	B																																		
PIN-3CD / 3CDP	0.087	0.146																																		
BPX-65	0.075	0.200																																		
OSD-Prefix Devices	0.080	0.200																																		

All units in inches. Pinouts are bottom view.

Low Profile

Products:
 PIN-10DI
 PIN-10DPI
 PIN-10DPI/SB
 UV-50L
 UV-100L

Pin Circle Dia.=0.73

BNC

Products:
 PIN-10D
 PIN-10DP
 PIN-10DP/SB
 UV-50
 UV-100

Outer Contact — Anode	PIN-10D, PIN-10DP, PIN-10DP/SB
Outer Contact — Cathode	UV-50, UV-100

BNC

Products:
 PIN-25D
 PIN-25DP

Outer Contact — Anode

Special BNC

Products:
 PIN-10AP
 PIN-10DF

P/N	A	B	C
PIN-10DF	0.217	0.330	1.020
PIN-10AP	0.386	0.550	1.415

Special Plastic

Products:
 FIL-5C
 FIL-20C
 FIL-UV20
 FIL-C4DG

P/N	A	B
FIL-5C FIL-20C	0.060	0.130
FIL-UV005 FIL-UV20 FIL-C4DG	0.087	0.152

P/N	1	2	3	4	5	6
FIL-5C FIL-20C FIL-UV005	a	-	c	a	-	c
FIL-UV20	c	-	a	c	-	a
FIL-C4DG	c	a	c	c	a	c

Special Plastic



Products:
 FIL-44C
 FIL-100C
 FIL-UV50
 FIL-UV100
 FIL-C10DG

P/N	A	B
FIL-44C FIL-100C	0.052	0.130
FIL-UV50 FIL-UV100 FIL-C10DG	0.090	0.155

P/N	1	2	3	4	5	6	7	8
FIL-44C FIL-100C	a	-	-	c	a	-	-	c
FIL-UV50 FIL-UV100	c	-	-	a	c	-	-	a
FIL-C10DG	c	a	a	c	c	a	a	c

Mechanical Specifications

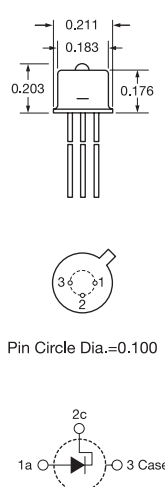
All units in inches. Pinouts are bottom view.

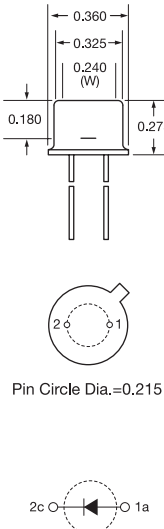
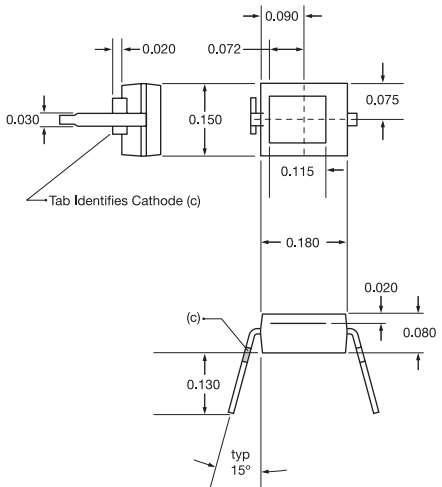
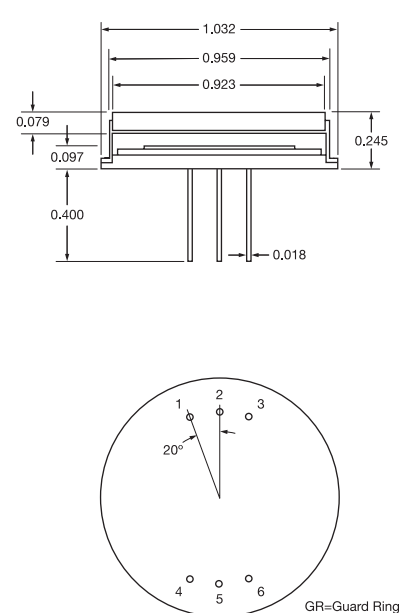
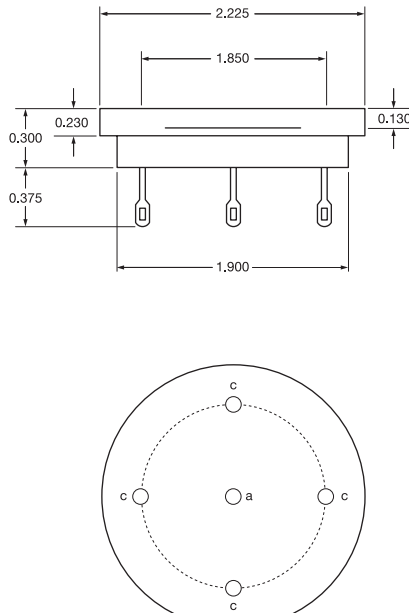
16 TO-18 Lensed Cap	17 TO-5	18 TO-5																												
<p>Products:</p> <p>PIN-HR005L PIN-HR008L PIN-HR020L PIN-HR026L PIN-HR040L</p>  <p>Pin Circle Dia.=0.100</p>	<p>Products:</p> <p>PIN-DSS PIN-DSIn</p>  <p>Pin Circle Dia.=0.220</p> <p>Bottom Diode Top Diode PIN-DSS</p> <p>Bottom Diode Top Diode PIN-DSIn</p>	<p>Products:</p> <p>PIN-005D-245F</p>  <p>Pin Circle Dia.=0.215</p>																												
19 Plastic Mold	20 Special Metal	21 Special Metal																												
<p>Products:</p> <p>BPW34 BPW34B</p>  <p>Tab Identifies Cathode (c)</p>	<p>Products:</p> <p>SPOT-15-YAG SPOT-9-YAG PIN-100-YAG</p>  <p>Pin Circle Dia.=0.750</p> <p>GR=Guard Ring</p> <p>Pinouts</p> <table border="1" data-bbox="584 1869 1023 1963"> <thead> <tr> <th>P/N</th> <th>1</th> <th>2</th> <th>3</th> <th>4</th> <th>5</th> <th>6</th> </tr> </thead> <tbody> <tr> <td>SPOT-15-YAG</td> <td>C1</td> <td>GR</td> <td>C4</td> <td>C2</td> <td>A</td> <td>C3</td> </tr> <tr> <td>SPOT-9-YAG</td> <td>C1</td> <td>GR</td> <td>C4</td> <td>C2</td> <td>A</td> <td>C3</td> </tr> <tr> <td>PIN-100-YAG</td> <td>--</td> <td>C</td> <td>--</td> <td>--</td> <td>A</td> <td>--</td> </tr> </tbody> </table>	P/N	1	2	3	4	5	6	SPOT-15-YAG	C1	GR	C4	C2	A	C3	SPOT-9-YAG	C1	GR	C4	C2	A	C3	PIN-100-YAG	--	C	--	--	A	--	<p>Products:</p> <p>SC-50D</p>  <p>Pin Circle Dia.=1.110</p>
P/N	1	2	3	4	5	6																								
SPOT-15-YAG	C1	GR	C4	C2	A	C3																								
SPOT-9-YAG	C1	GR	C4	C2	A	C3																								
PIN-100-YAG	--	C	--	--	A	--																								