

FCI-GaAs-XXM

High Speed GaAs Arrays

The FCI-GaAs-XXM is a 4 or 12 element GaAs PIN photodetector array designed for high speed fiber receiver and monitoring applications. The 70 μ m diameter elements are capable of 2.5Gbps data rates. AR coated and sensitive to telecommunication wavelengths, this array is a perfect receiver for SM or MM fiber ribbon with a 250 μ m pitch. The FCI-GaAs-XXM comes standard on a wraparound ceramic submount. Board level contacts have a 0.5mm pitch.

If you need a custom array or require special testing for your OSI Optoelectronics part, please contact our Applications department.

FCI-GaAs-12M

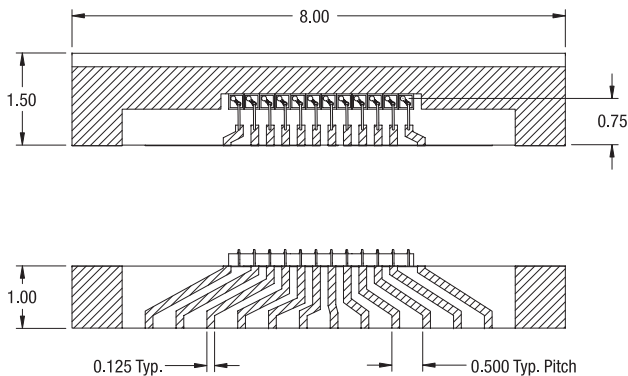

FCI-GaAs-4M

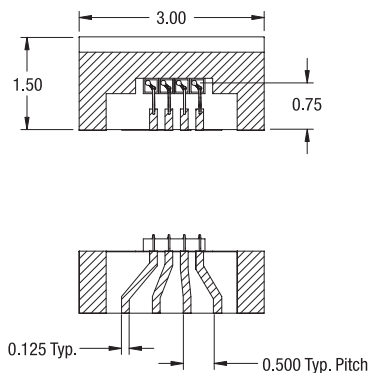

Notes:

- All units in millimeters.
- All devices are mounted with low out gassing conductive epoxy with tolerance of $\pm 25\mu$ m.

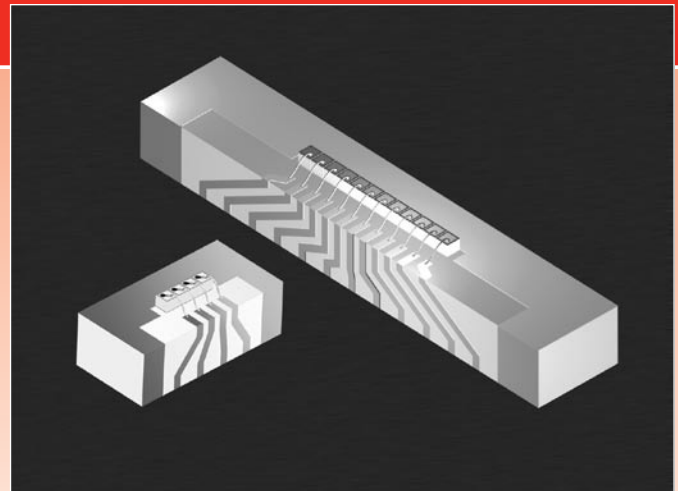

APPLICATIONS

- Fiber Optic Receiver
- DWDM Monitor
- SM or MM Fiber Ribbon
- Parallel Interconnects

FEATURES

- High Speed
- High Responsivity
- AR Coated Elements
- Wraparound Ceramic Submount
- Spectral Range 650nm to 860nm

Electro-Optical Characteristics

$T_A = 23^\circ\text{C}$, $V_R = 5\text{V}$

PARAMETERS	FCI-GaAs-4M	FCI-GaAs-12M
Active Area Diameter	70 μ m, Pitch:250 μ m	
Responsivity	Typ. 0.63A/W @850nm	
Capacitance	Typ. 0.65pF	
Dark Current	Typ. 0.03nA	
Max. Reverse Voltage	20V	
Max. Forward Current	5mA	
Bandwidth	Typ. 2.0GHz @ 850nm	
Breakdown Voltage	Typ. 50V	
Storage Temperature Range	From -40 to 85°C	
Operating Temperature Range	From 0 to 70°C	