



PIGTAIL STYLE LASER TO FIBER COUPLERS

FEATURES:

- Excellent Coupling Efficiency up to 90%
- Excellent Polarization Maintaining Capabilities up to 35dB
- Rugged, Compact, Stable Design
- Low Backreflection
- Low Cost
- Environmentally Stable
- Wide Wavelength Ranges 200nm - 2100nm
- Adjustable Output Power

APPLICATIONS:

- Interferometric Sensors
- Medical, Pharmaceutical, and Chemical Sensors
- Fluorescence Measurements
- Spectroscopy
- Laser Shows/Entertainment
- OEM Laser Systems

SPECIFICATIONS:

- Coupling Efficiency: Typically >60% into Singlemode or Polarization Maintaining fibers
>80% for multimode fibers
- Backreflection Levels: <-35dB for multimode fibers
<-40dB for Singlemode and Polarization Maintaining fibers
-60dB versions are also available
- Polarization Extinction Ratios: >20dB
25dB and 30dB versions are also available
- Available Wavelengths: 200nm - 2100nm
- Power Handling: >1 Watt CW for GRIN lenses
>5 Watts CW for achromat lenses
>10 Watts CW for aspheric lenses
>100 Watts CW for fused silica or sapphire plano-convex and biconvex lenses (multimode fibers)
>100 Watts CW for axial GRIN lenses (SM, PM, and LMA filters)

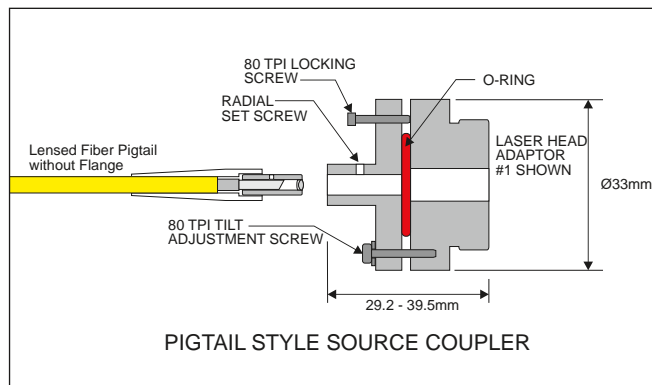

PRODUCT DESCRIPTION:

Pigtail style source couplers are recommended for permanent or semi-permanent situations, where optimum coupling efficiency, output stability, and minimum backreflection are desired. In these couplers the fibers are permanently glued to the focusing lens. The fiber-lens assembly is then inserted into the tilt adjustment flange, and held in place with two radial set screws.

Because the fiber is permanently attached to the lens, the fiber cannot be replaced without also replacing the coupling lens.

In pigtail style couplers the internal endface of the fiber is polished at an angle to reduce backreflection. This ensures <-40dB backreflection. By adding an anti-reflection coating to the inner fiber tip, backreflection can be further improved to -60dB.

ORDERING INFORMATION:

LPSC-03-W-a/b-F-f-LH-LB-X-JD-L

Wavelength: Specify in nanometers
(Example: 633 for 633nm)

Fiber Core/Cladding Sizes, in microns
9/125 for 1300/1550nm SM fiber
See Tables 1 to 5 of the *Standard Tables* for other standard fiber sizes
http://www.ozoptics.com/ALLNEW_PDF/DTS0079.pdf

Fiber Type: M for Multimode
S for Singlemode
P for Polarization Maintaining

Lens Type: See the *Lens Selection Guide 1* for Pigtail Style Source Couplers in the *Laser to Fiber Coupler Application Notes*
http://www.ozoptics.com/ALLNEW_PDF/DTS0108.pdf
http://www.ozoptics.com/ALLNEW_PDF/APN0004.pdf

Laser Head Adaptor
1 for 1"-32TPI Male Threaded Adaptor
2 for Disk Adapter with 4 holes on 1" square
11 for Post Mount Adapter

See Table 8 of the *Standard Tables* for other adaptors
http://www.ozoptics.com/ALLNEW_PDF/DTS0079.pdf

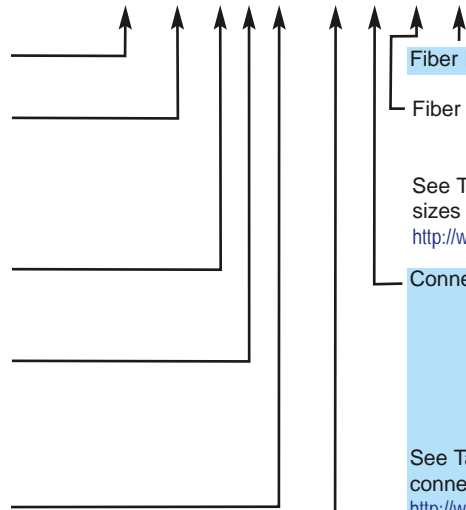

Fiber Length in meters

Fiber Jacket Type: 1=900 micron OD hytel jacket
3=3mm OD Kevlar reinforced PVC cable

See Table 7 of the *Standard Tables* for other jacket sizes
http://www.ozoptics.com/ALLNEW_PDF/DTS0079.pdf

Connector Code: 3S = Super NTT-FC/PC
3U = Ultra NTT-FC/PC
3A = Angled NTT-FC/PC
8 = AT&T-ST
8S = Super AT&T-ST
SC = SC
SCA = Angled SC

See Table 6 of the *Standard Tables* for other connectors
http://www.ozoptics.com/ALLNEW_PDF/DTS0079.pdf

Backreflection: 40 or 60dB
60dB versions standard only for 1300 and 1550nm wavelengths. Contact OZ before specifying other wavelengths.

Note: Add "-ER=30" or "-ER=25" to the part number for 30dB or 25dB extinction ratios (For 1300nm and 1550nm only).
Add "-BL" to the part number if a manually adjustable attenuator is to be added.

NOTE:

To determine the best laser to fiber source coupler for your application please complete a *Laser to Fiber Delivery System Questionnaire* http://www.ozoptics.com/ALLNEW_PDF/QTR0002.pdf. OZ Optics will then recommend a coupler based on your response.

Unit prices range from \$125USD to \$400USD for typical applications with delivery being from stock to within 2 weeks of receiving your order. Quantity discounting and blanket orders can be arranged. Contact OZ for more information.

For standard parts, please see our online catalog <http://shop.ozoptics.com>

Lens Selection Guide for Laser to Fiber Couplers can be found: http://www.ozoptics.com/ALLNEW_PDF/DTS0108.pdf

Laser Head Adapter Drawings can be found: http://www.ozoptics.com/ALLNEW_PDF/DWG0001.pdf

Standard Tables can be found: http://www.ozoptics.com/ALLNEW_PDF/DTS0079.pdf

Laser to Fiber Source Couplers - Application Note can be found: http://www.ozoptics.com/ALLNEW_PDF/APN0004.pdf

ALIGNMENT KITS:

The following alignment kits are recommended for receptacle style laser to fiber couplers for 400-2000nm:

Bar Code	Collimator Housing Size	Part #
31580	4mm	START-01/4-DVD-IRVIS
29755	8mm	START-01/8-DVD-IRVIS
28987	12mm	START-01/12-DVD-IRVIS

TORQUE WRENCH:

Handheld torque wrench set to 1 in/lb with a 0.050" ball driver on the output.

Bar Code	Part #
21092	TORQUE-WRENCH-1-0.050BD